

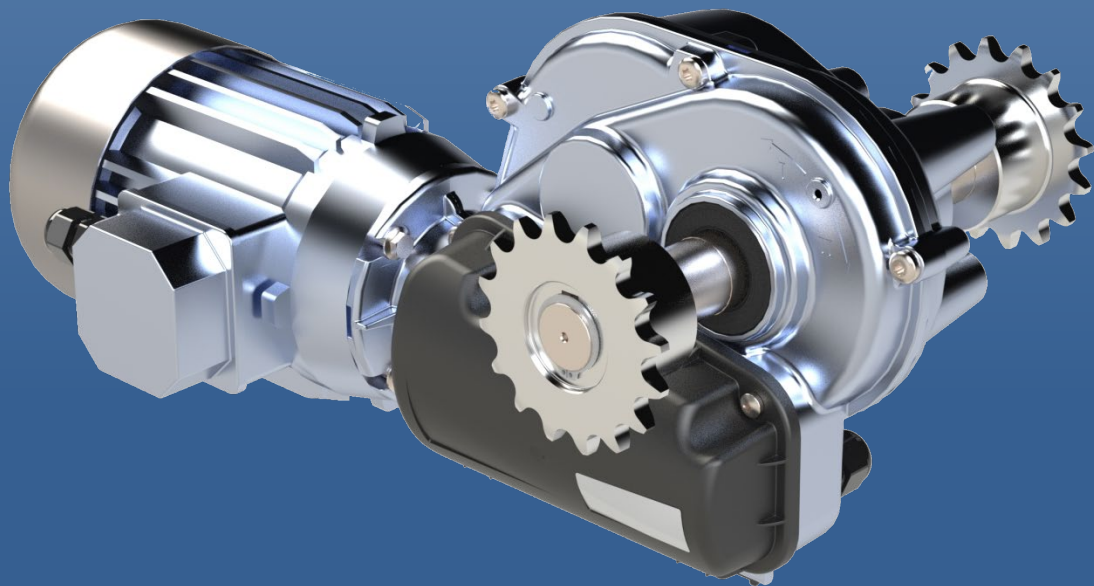

GWM Installation manual



Declaration of incorporation in accordance with the European Machinery Directive 2006/42/EC, Annex II, No. 1B

DE GIER B.V.
WESTLANDSEWEG 9
NL-2291 PG WATERINGEN
THE NETHERLANDS

We hereby declare that pursuant to article 2G the following partly completed machines are exclusively intended to be integrated into or mounted in another machine or piece of equipment:

Motor: GWM15 / GWM30 / GWM45

The specific technical documents pursuant to annex VII B have been drawn up and shall be sent on request by post to the national authorities.

This partly completed machine is compliant with the provisions of the following European directives:

European Machinery Directive 2006/42/EC
European EMC Directive 2004/108/EC

The following harmonised standards (or parts of these standards) have been applied:

EN ISO 12100-1, -2: 04/2004

Safety of machinery: Basic terms, general design principles

EN ISO 14121-1:12/2007

Safety of machinery: Risk assessments

EN 60204-1:06/2007

Safety of machinery: Machinery electrical equipment

EN 60034-5:09/2007

Rotating electrical machines (only electric motors)

This partly completed machine may only be commissioned if it has been established that the machine into which this partly completed machine needs to be built satisfies the provisions of the machinery directive.

Authorised compiler of the technical documents:

Rob Sandberg
Managing Director De Gier B.V.
Wateringen, 12-01-2018

Index

Index.....	3
Dimensions.....	4
Technical specifications.....	4
1. Explanation of symbols and safety instructions.....	5
2. Product.....	7
3. Instructions for use.....	8
4. Installation and connection.....	10
5. Commissioning.....	15
6. Inspection and maintenance.....	17
7. Warranty.....	18
8. Quick Troubleshooting.....	19
9. Wiring diagram 400V 3~ supply.....	20
Glossary.....	21

Thank you

for choosing a gearbox from De Gier Drive Systems' GWM series.

Please pay careful attention to the information in the installation manual during installation and set-up. If you have any questions or come across problems, please do not hesitate to contact us.

Our service number is: +31 174 - 29 20 89

Or by e-mail: sales@degier.nl

De Gier Drive Systems

Dimensions

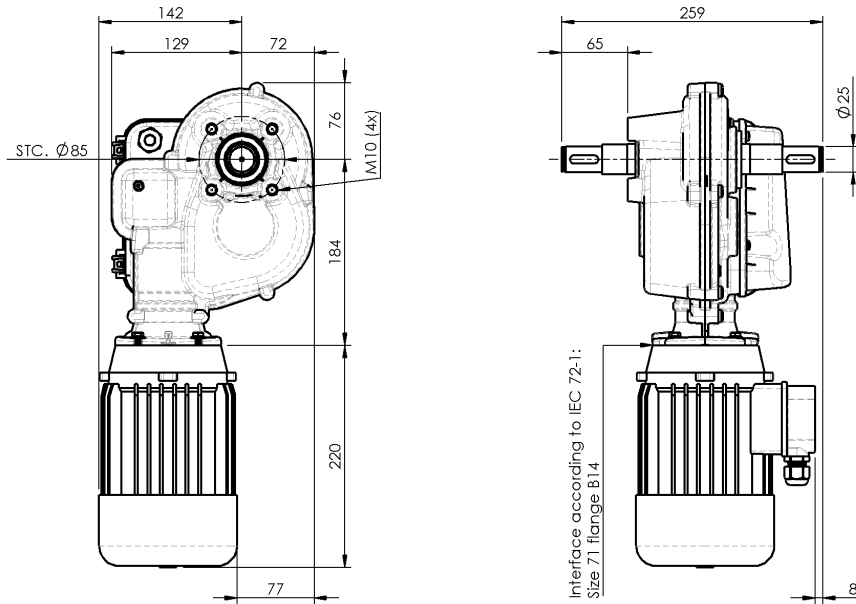

Technical specifications



Article number	Torque	50 Hz				60 Hz				Mass
		Speed	Power	Voltage	Current	Speed	Power	Voltage	Current	
		T_2 [Nm]	n [rpm]	P [kW]	U [V]	I [A]	n [rpm]	P [kW]	U [V]	
P.GWM15.1.400.26.K	150	2,6	0,18	230 / 400 (~3)	1,2 / 0,7	3,1	0,22	277 / 480 (~3)	1,2 / 0,7	14,1
P.GWM15.1.400.26.KW	150	2,6	0,18	230 / 400 (~3)	1,2 / 0,7	3,1	0,22	277 / 480 (~3)	1,2 / 0,7	16,4
P.GWM15.1.400.52.K	150	5,2	0,25	230 / 400 (~3)	1,4 / 0,8	6,2	0,30	277 / 480 (~3)	1,4 / 0,8	14,3
P.GWM15.1.400.52.KW	150	5,2	0,25	230 / 400 (~3)	1,4 / 0,8	6,2	0,30	277 / 480 (~3)	1,4 / 0,8	16,6
P.GWM30.1.400.26.K	300	2,6	0,25	230 / 400 (~3)	1,4 / 0,8	3,1	0,30	277 / 480 (~3)	1,4 / 0,8	14,5
P.GWM30.1.400.26.KW	300	2,6	0,25	230 / 400 (~3)	1,4 / 0,8	3,1	0,30	277 / 480 (~3)	1,4 / 0,8	16,8
P.GWM30.1.400.52.K	300	5,2	0,37	230 / 400 (~3)	1,7 / 1,0	6,2	0,44	277 / 480 (~3)	1,7 / 1,0	14,7
P.GWM30.1.400.52.KW	300	5,2	0,37	230 / 400 (~3)	1,7 / 1,0	6,2	0,44	277 / 480 (~3)	1,7 / 1,0	17,0
P.GWM45.1.400.26.K	450	2,6	0,37	230 / 400 (~3)	1,7 / 1,0	3,1	0,44	277 / 480 (~3)	1,7 / 1,0	14,9
P.GWM45.1.400.26.KW	450	2,6	0,37	230 / 400 (~3)	1,7 / 1,0	3,1	0,44	277 / 480 (~3)	1,7 / 1,0	17,2



Article number	Electric motor interface	Maximum output torque	Allowed nominal input torque	Allowed maximum input torque	Allowed maximum input speed	Ratio	Setting range of number of output shaft revolutions	Mass
	IEC 72-1 [-]	T_2 max [Nm]	T_1 nom [Nm]	T_1 max [Nm]	n max [rpm]	i [-]	s [-]	
P.GWMR.1.26.K	IEC71 B14	450	3,0	6,0	1800	505	0,75 – 42	8,7
P.GWMR.1.26.KW	IEC71 B14	450	3,0	6,0	1800	505	0,75 – 42	11,0
P.GWMR.1.52.K	IEC71 B14	300	3,0	6,0	1800	264	1,50 – 84	8,5
P.GWMR.1.52.KW	IEC71 B14	300	3,0	6,0	1800	264	1,50 – 84	10,8

1. Explanation of symbols and safety instructions

Explanation of symbols and instructions in this manual

Important procedures are emphasised in this user manual in a separate box with the initial lines printed in bold. See below for an explanation of the various instructions you will encounter in this manual.



Symbol	Meaning	Unit
T	Torque	Nm
P	Power	kW
U	Voltage	V
I	Current	A
	Tip	-
	Note	-



Symbol	Meaning	Unit
n	Rotational speed	rpm
L	Length	mm
m	Mass	Kg
	Hazard	-
	Electrical	-

Instruction	Explanation
Tip	Gives the user suggestions and advice for carrying out specific tasks easily or more practically.
Attention!	Remarks with supplementary information for the user. These remarks draw the user's attention to potential problems.
Caution!	Material damage can occur when the procedures are not followed carefully.
Warning!	Serious injury to the user and/or serious damage to the product can occur if the procedures are not followed carefully.
Risk of injury or death!	The user's life is directly endangered

Explanation of symbols on the motor gearbox

The following symbols are shown on the motor gearbox.

Symbol	Meaning
	Do not spray
	Electrically live parts
	Read the documentation

Symbol	Meaning
	Remove the yellow vent screw
	PE connection point (earth)

Installation

- Read this installation manual carefully and in full;
- Check that the delivery is complete before starting to install the motor gearbox;
- Strictly observe the step-by-step procedures set out in the installation manual;
- Observe all of the information in the installation manual, in particular all information relating to safety, use, maintenance and servicing;
- Switch off power to the motor gearbox before starting to work on the motor gearbox or in its immediate vicinity;
- Improper installation, commissioning, maintenance etc. of the motor gearbox can lead to personal injury and/or material damage due to the high torque of the motor gearbox;
- Operate the motor within its electrical ratings to avoid damage to the motor, drive train or other parts of the system.

General safety instructions

- Switch the power off before starting to work on the motor gearbox or the system and lock it out (for example, with a padlock) to prevent it from being switched back on. This also applies to auxiliary circuits, such as limit switches or standby heating. It is not sufficient to switch off the controller by selecting 'stop' or '0'. The motor gearbox may also continue to operate in the «Stop» or «0» position in response to higher-level functions, such as signals from wind or rain sensors;
- With attached or driven components there is a risk of becoming trapped or injured. Amongst other things, the safety distances set out in EN 349 and EN 13857 must be observed and suitable precautions must be taken, such as safety devices or a dead-man vigilance system;
- Do not allow people to stand under or close to suspended loads;
- Attached or driven parts may have a shorter service life than the motor gearbox itself;
- De Gier supplies motor gearboxes that are self-braking, but this function may not be effective under certain conditions. We strongly recommend that for hoisting applications you use a motor gearbox equipped with a mechanical brake and mount a fall-arrest brake on the drive shaft;
- Never loosen screws, couplings or other parts while the drive train is loaded externally;
- Also observe national legislation and guidelines regarding working conditions and safety;
- Clean up the hazard area and leave it before switching the power back on;
- Despite careful planning and compliance with all regulations, some risks cannot be prevented.

Qualified staff

All activities described below must be performed by qualified staff. Qualified staff means persons who, based upon their training, experience and/or education, have obtained sufficient knowledge of the applicable standards, provisions, accident prevention regulations and operating conditions and are thus able to identify and avoid potential hazards during relevant activities (for instance, installers recommended by De Gier). Approval by the safety officer for the overall plant or system is always required before work may be carried out.

2. Product

Manufacturer

The address details of De Gier are set out below;

De Gier B.V. Westlandseweg 9 NL-2291 PG Wateringen The Netherlands	I: www.degier.eu E: sales@degier.nl T: +31 174 – 292 089 F: +31 174 – 295 644
---	--

Identification plate

Example of an identification sticker which is fitted on every GWM.

		De Gier B.V. 7 → The Netherlands www.degier.eu	
1 →	Article no. : P.GWM30.1.400.26.K		
2 →	Motor no. : 1801762 / 005261 ← 4	6 →	
3 →	Date : 14/01/2018	5 →	

1. Article number
2. Motor identification number
3. Production date
4. Serial number
5. De Gier barcode
6. De Gier QR-code
7. Company information

Article number

The structure of the article number on the above rating plate is set out below with an explanation of the possible versions.

Code	Series	Torque [x 10 Nm]	Version	Voltage [V]	Speed @ 50 Hz [x 0,1 rpm]	Accessories
P	GWM	30	1	400	26	K

Possible series		Possible versions	
GWM	GWM with electric motor mounted	K	No chain sprockets on output shaft
GWMR	GWM without electric motor mounted	KW	Chain sprockets incl. chain

Materials and parts of the gearbox

Gearbox parts	Material
Gear wheels, shafts, bearings, retaining rings, ...	Steel
Gear unit housing, housing parts	Aluminium
Worm gears	Bronze
Shaft seals, sealing caps	Elastomer (with steel)
Gaskets	Silicon
Limit switch and protective cover	Plastic
Gear oil	Enriched mineral oil

3. Instructions for use

Intended use

GWM motor gearboxes are intended for ventilation and screening applications such as:

- Ridge ventilation: linear-drive roof ventilation systems, for example in greenhouses, poly-tunnels garden centres, office buildings or halls;
- Side ventilation: linear-drive side ventilation systems, for instance in greenhouses, facades, halls, or roll-up curtains or plastic tarps for greenhouses;
- Screening: for example, screens driven by cables or toothed racks in greenhouses or strip curtain systems;

Conditions of use

The following conditions of use are applicable when using the motor gearbox:

- Operating ambient temperature range is 0°C to +60°C [32°F to 140°F];

Warning! Risk of burns!



The outside of the drive unit can reach temperatures in excess of 60°C (140°F). We recommend fitting a protective cover if the unit is within easy reach.

- Max. force on output shaft radial 4000 N, axial 400 N
- The gearbox is not suitable for continuous operation.
- The gearbox is suitable for S3-30% operation;
- The maximum continuous on time is 25 minutes;
- The motor gearbox may be cycled a maximum of 3 times per minute;
- The service life of the motor gearbox increases significantly with low loads and switching cycles which allow intermediate cooling of the motor gearbox.

Restrictions on use

Structural modifications to the motor gearbox are not permitted. Any such modifications render the manufacturer's warranty null and void and relieve the manufacturer of liability for any consequences. In addition, the following restrictions are applicable with regard to the use of the motor gearbox:

- Do not load the motor gearbox or drive train with a torque greater than specified;
- Do not use the motor gearbox to operate parts located in the immediate vicinity (within easy reach) of people.
Maintain safe distances in accordance with EN ISO 13857;
- Do not expose the motor gearbox to direct water spray, rain or snow;
- Do not use the motor gearbox to operate smoke and heat exhaust ventilation systems compliant with NEN 6093 or DIN 18232;
- Do not use the motor gearbox to operate automatic doors or gates used by people;
- Do not use the motor gearbox in explosion hazard areas if express permission has not been granted to do so.

Unintended use

We expressly warn against the following types of unintended use:

- Do not use the motor gearbox for lifting suspended loads especially in areas in which people are present;
- Do not use the motor gearbox for transporting people (for example, for passenger lifts, etc.).

Transport

To safeguard the service life and correct functionality of our products, the following rules must be followed:

- Transport the gearbox carefully and avoid shocks.
- Force causes damage to the gearbox.
- Use a work platform, or lift the gearbox using hoisting equipment and appropriate slings fitted around the output shaft.



Risk of injury or death! Falling objects can present a danger to people!

Storage

To safeguard the service life and correct functionality of our products, the following rules must be followed:

- Ensure that the motor gearboxes are stored in a dust-free and moisture-free environment;
- The relative air humidity of the storage location must be less than 60%;
- Store the motor gearboxes at temperatures between -15 and +60°C [5°F to 140°F];
- Avoid sudden changes in temperature to prevent the formation of condensation.

If you wish to store the motor gearboxes for a lengthy period of time, you can use preservatives to protect the unpainted surfaces, such as threaded holes and mounting surfaces for chain couplings, against corrosion.

Disposal

Drain used oil from the motor gearbox. Used oil must be collected, temporarily stored, transported and replaced properly. Observe national legislation. Collect waste oil and dispose of it in accordance with regulations. Clean up any spilled oil immediately using a suitable emulsifier or absorbent material.

Caution!



Improper disposal of waste oil is hazardous to the environment and to health. Used oil must be taken to a collection point for waste oil. Avoid prolonged skin contact.

Dispose of housing parts, gear wheels, shafts and roller bearings of the transmission as scrap metal. The worm gears may contain black non-ferrous metal alloys and must be disposed of accordingly. Dispose of the packaging materials in accordance with regulations or bring them to a recycling station.

4. Installation and connection

Installation of the motor gearbox and adjustment of the limit switches may only be carried out by qualified staff, see section 1.

Installation positions and vent plug

Consider the following points when determining the installation position:

- Maintain a clearance of approximately 500 mm above the protective cover for adjusting the limit switch;
- Keep approximately 100 mm of space free behind the motor so that in the event of a power failure the electric motor can be removed and the gearbox can be operated manually or with a drill (maximum speed 800 rpm) using the 22 mm hex nut on the input shaft;

Every gear unit is pre-filled during assembly with the correct type and quantity of oil. Every gear unit is also fitted with two screw plugs. Remove the upper yellow screw after mounting but before using the gearbox.

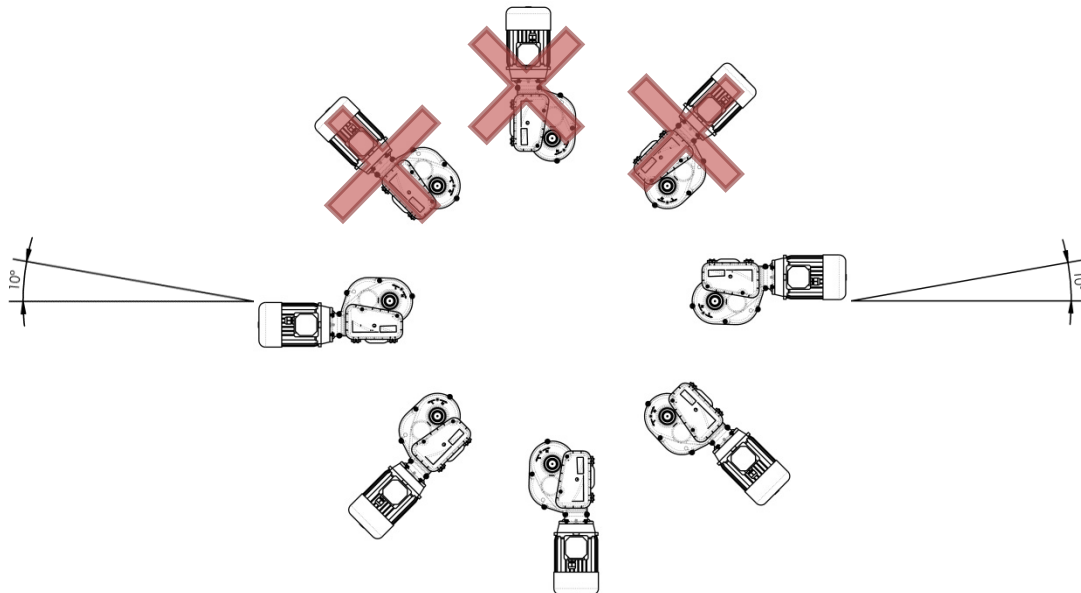

Mounting the motor gearbox

Secure the gearbox with four bolts and apply a torque of 40 Nm to 50 Nm to tighten the bolts. Use M10 bolts with a strength class of 8.8 according to ISO 4014, threaded length in the gearbox of 10 to 15 mm.

If wood screws or wall anchors are used for mounting, the right screws and tightening torques must be determined by the installer. These mounting materials must provide the same clamping force as the M10 bolts with a strength class of 8.8 according to ISO 4014, tightened at 40 Nm to 50 Nm of torque.

Attention! The output shaft and the drive train must be in a single line.



If alignment errors cannot be avoided, use a flexible coupling.

Mounting the electric motor

Mounting the electric motor may only be carried out by qualified staff, see section 1.

Electric motors with an interface corresponding with IEC 72-1 size 71 will fit the gearbox. Maximum allowable input torque is specified for each gearbox in the technical specification; make sure that the electric motor does not exceed these specifications.

Secure the electric motor with four M6x16 bolts with a strength class of 8.8 according to ISO 4014 and apply a torque of 10 Nm to 15 Nm to tighten the bolts.

Attention! Do not forget to place the parallel key in the key slot of the electric motor shaft.



The gearbox will not function and could get damaged when the parallel key is not fitted.

Electrical connection

Connecting and commissioning may only be carried out by qualified staff.

Risk of injury or death due to electrical or mechanical forces!



Before starting to work on the gearbox or related parts, always switch the power off at the master switch or operating switch and lock it with a padlock to prevent switching on again.

Mains connection for three-phase AC motors

The wiring diagram can be found in section 9.

Attention!



Swapping the supply voltage phase connections changes the direction of rotation of the drive. This changed direction will not correspond with the control circuit which is connected to the limit switch.

1. Remove the cover from the terminal block of the electric motor;
2. Insert the cable through the cable gland and rubber gasket;
3. Connect the green/yellow lead to the PE terminal (earth);
4. Connect phase L1 to terminal U1, phase L2 to terminal V1 and phase L3 to terminal W1 (see diagram);
5. Check the direction of rotation of the output shaft in relation to the limit switch and the control cabinet, and swap two phases if necessary;
6. Fit the terminal block cover and gasket back on the motor and tighten the cable gland;
7. Make sure that the cables are clear of any moving parts.

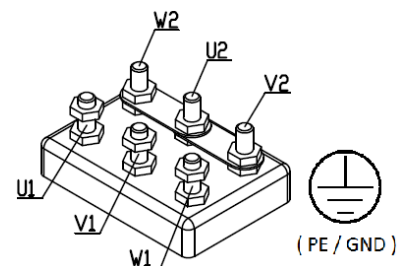

Connecting the limit switch

1. Remove the plastic protective cover from the gearbox;
2. Insert the cable through the cable gland;
3. Connect the working and emergency switches as indicated in the diagram below;
4. Make sure that the cables are free and tighten the cable gland;
5. Re-fit the plastic protective cover on the gearbox.

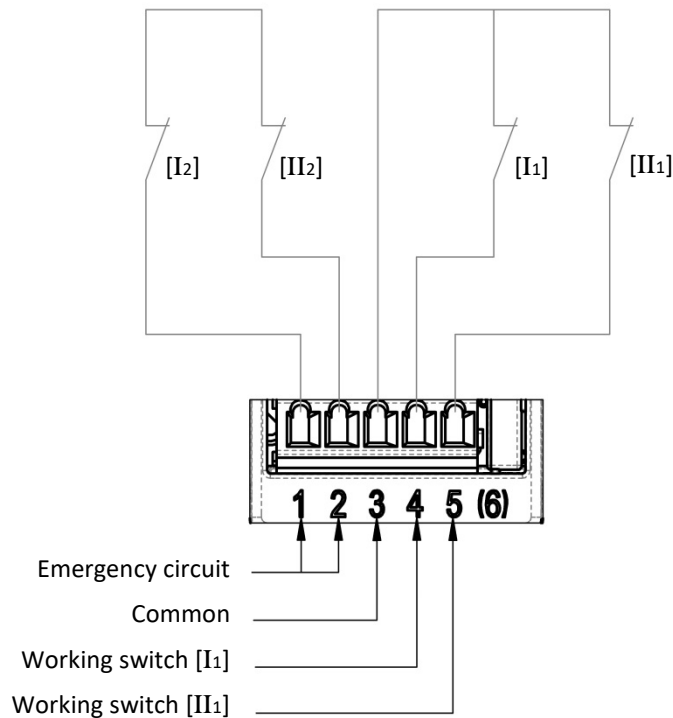
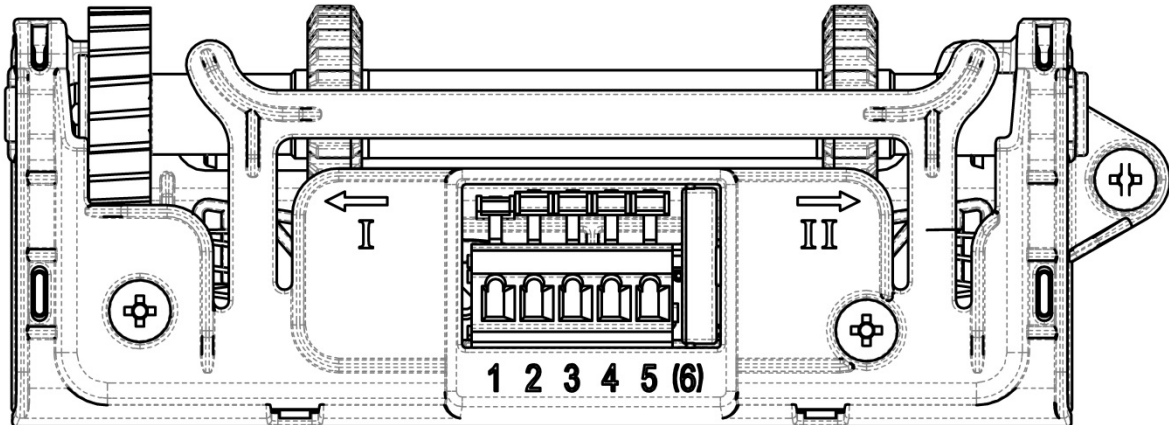

Mounting the chain coupling

The gearbox is normally coupled to the load by chain coupling to the drive shaft. See the details below for maximum torque and maximum alignment error.

Type of chain coupling	Max. torque [Nm]	Max. angle
10B Z16 (5/8" x 3/8")	420	4°

Warning



- Do not exceed the maximum rated torque of chain couplings and accessories.
- The load must be distributed evenly over both ends of the shaft. Preferably fit the drive unit in the middle of the drive train.
- The maximum angle a chain coupling is allowed to make must remain below the specified value.

1. Mount the chain sprockets of the coupling on the output shaft and the drive tube;
2. Turn the chain sprockets of the coupling until the teeth are aligned;
3. Wrap the dual chain around the teeth of the sprockets, the ends of the chain should be on top of the coupling;
4. Fit the chain as shown in the diagram below.

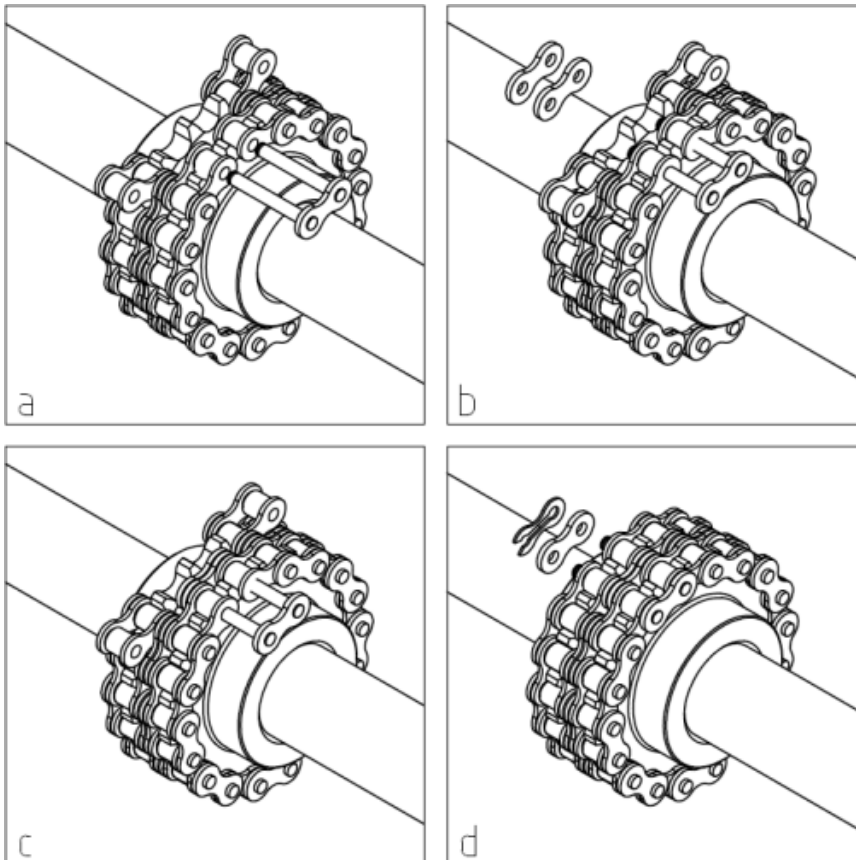

Replacing the limit switch

1. Remove the protective [B] cover from the motor gearbox;
2. Remove the old limit switch by removing the three screws;
3. Fit the new limit switch in its intended position;
4. Secure the limits switch by screwing the three screws hand-tight;
5. Follow the adjustment procedure on page 15 to set the limit switch.

Dismounting the motor gearbox from the system

Dismounting may only be carried out by qualified staff, see section 1.

Risk of injury or death due to electrical or mechanical forces!



Before starting to work on the gearbox or related parts, always switch the power off at the master switch or operating switch and lock it out with a padlock to prevent switching on again.

Risk of injury or death due to falling objects!



Cordon off the hazard area with barrier tape. Use a work platform, or lift the gearbox using hoisting equipment and appropriate slings fitted around the output shaft.

Attention!



Motor gearbox components may only be replaced or repaired by an authorised service representative of De Gier.

1. Set the system in a certain position in which the driveshaft and gearbox is not mechanically loaded, for example with the vent closed;
2. Disconnect all wiring;
3. Disconnect the output shaft from the driven system;
4. Plug the oil vent hole with a ISO 4014 M4 screw, for example the yellow screw it came with;
5. Dismount the gearbox unit from its support.

5. Commissioning

After the gearbox has been installed and connected, a test run in the system is necessary. Pay attention to the following points during the test run:

1. Ensure that no people or objects are within the working area of the gearbox and connected parts;
2. Check whether the upper yellow vent screw is removed from the gearbox.
3. Check the operation of the system in manual mode. The direction of movement must match the indication on the control panel;

Caution!



Operate the drive in manual mode at first; not in automatic mode.

Limit switch functionality description

- The spindle [C] of the limit switch mechanism is driven by a worm gear from the secondary shaft of the gearbox.
- The limit switch [A] has two switch nuts [D] which move along the spindle [C] in direction I or II, depending on the direction of rotation of the motor gearbox. Direction markings on the limit switch correspond with the rotation markings on the gearbox housing.
- The two switch nuts [D] of the mechanism which will actuate the working switch and emergency switch: either working switch [I₁] and emergency switch [I₂] for direction I, or working switch [II₁] and emergency switch [II₂] for direction II.
- The emergency switch [I₂] or [II₂] is an auxiliary device and is only actuated when the working switch [I₁] or [II₁] does not stop the motor gearbox in time. The electrical connection diagram can be found on the inside of the plastic protection cover [B] and in section 4 of this manual.
- The locking lever [E] prevents the switch nuts [D] from rotating when the spindle [C] is driven by the gearbox.
- To ensure proper functioning of the limit switch mechanism, the protection cover has to be mounted and screwed in place with two screws.

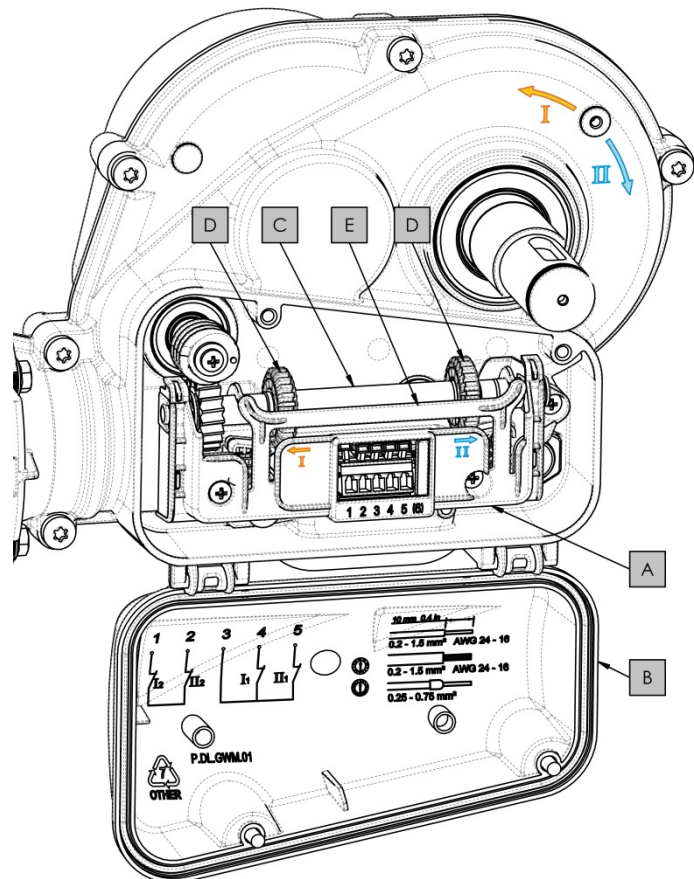

Adjustment procedure

1. Make sure the gearbox, electric motor and limit switch are properly mounted and connected;
2. Remove the protective cover [B] to reveal the limit switch [A];
3. Rotate the gearbox and determine which direction [I] or [II] points to the start position of the system;
4. Rotate the gearbox to the start position and stop at the desired position;

Caution!



When driving the gearbox with a 22 mm hex socket, keep the speed below 800 rpm to avoid damage to the hex nut on the input shaft of the gearbox.

5. The locking lever [E] should be slightly lifted to set the limit switch; this allows the switch nut [D] to rotate. Rotate the switch nut [D] which is closest to the end of the spindle [C] of the direction of choice (direction [I] of [II]) until you hear a click;

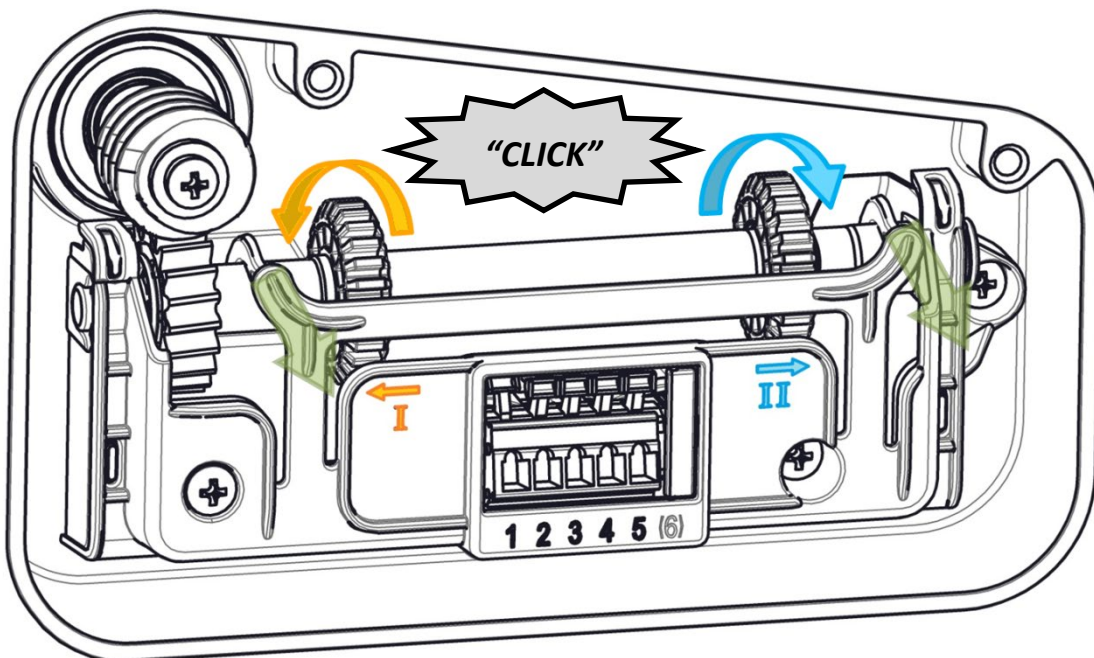

Caution!



Avoid lifting the locking lever [E] too far, as the locking lever might not fully return and prevent the switch nuts from rotating with the switch shaft.

6. Lower the locking lever [E] and let it settle on one of the grooves of the switch nut;
7. Rotate the gearbox until the output shaft has made half a revolution in the opposite direction;
8. Rotate the gearbox towards the desired position and verify the settings of the limit switch;
9. If necessary it is possible to fine tune the setting of the limit switch by rotating the switch nut one groove in either direction;

10. Repeat step 7 to 9 to fine tune the limit switch setting if necessary;
11. Rotate the gearbox to the end position and stop at the desired position;
12. Repeat steps 5 to 10 to set the limit switch for the end position. The limit switch is now properly set for operation;
13. Mount the protective cover [B] on the gearbox and tighten the two screws;

Attention!

Do not store loose parts or documents under the protective cover. This could damage and influence the functionality of the limit switch.

14. Verify the limit switch settings by operating the electric motor;
15. Keep this manual with adjustment instructions in a suitable place.

6. Inspection and maintenance

Inspection and maintenance tasks may only be carried out by qualified staff, see section 0.

Maintenance intervals

Every 6 months

- Check for increased noise level;
- Lubricate chain couplings (oil viscosity 80 cST to 120 cST at 20°C).

Every year

- Check and re-tighten mounting bolts;
- Check couplings for wear and corrosion;
- Check the wiring of the motor and the limit and emergency switch mechanism;
- Check worm gear wear and shaft play.

Risk of injury or death due to electrical or mechanical forces!

Before starting to work on the gearbox or related parts, always switch the power off at the master switch or operating switch and lock it out with a padlock to prevent switching on again.

Maintenance tasks

The gearbox has lifetime lubrication. Changing the gear oil is usually unnecessary.

Caution!



For the following tasks it must be ensured that the load cannot start moving by itself after it is disconnected from the drive.

Checking worm gear wear and shaft play

1. Set the system in a certain position in which the driveshaft and gearbox is not mechanically loaded, for example with the vent closed;
2. Switch of the power;
3. Disconnect the gearbox from the drive train, so the output shaft should be able to turn freely;
4. Check the play in the gear unit by turning the output shaft of the drive.

If there is clearly noticeable play, the drive should be dismantled and return to the manufacturer for inspection.

Spare parts and parts replacement

Parts may only be replaced by qualified staff. Always use original spare parts and original lubricants. For product safety reasons, De Gier only supplies gearboxes and limit switches as replacement parts. Gear unit parts may only be replaced or repaired by an authorised service representative of De Gier.

7. Warranty

We only accept liability for original spare parts supplied by us. The warranty terms and conditions are the same as the standard "Metaalunie" conditions. These conditions are listed on the back of the quotation and invoice forms.

An additional copy of terms and conditions can be sent to you free of charge on request. We reserve the right to make modifications.

8. Quick Troubleshooting

Troubleshooting may only be performed by qualified staff, see section 1. For an extensive troubleshooting document, please contact your installer.

Risk of injury or death due to electrical or mechanical forces!



Before starting to work on the gearbox or related parts, always switch the power off at the master switch or operating switch and lock it out with a padlock to prevent switching on again.

In case of a power outage

- Disconnect power to prevent unintentional operation of the gearbox during work activities;
- In emergency situations the gearbox can be turned to the desired position by removing the electric motor and using a 22 mm hex socket to drive the input shaft of the gearbox using an electric drill or hand crank.

Caution!



When driving the gearbox with a 22 mm hex socket, keep the speed below 800 rpm to avoid damage to the hex nut on the input shaft of the gearbox.

Fault: drive does not run

- Check the motor protection switch and its settings. If the fault occurs again, there may be an overload;
- Check whether the emergency switch of the motor gearbox is actuated;
- Check the wiring, including the limit switch wiring;

Fault: travel past end position

- Check whether the locking lever is preventing the switch nuts from rotating;
- Re-adjust the limit switches if necessary, see section 5.
- Check the operation of limit switches [I₁] and [II₁] and emergency switches [I₂] and [II₂]. The switches must be wired and monitored as normally closed (NC) contacts;
- Check the operation of the relay and replace it if necessary.

Fault: oil leak

- Check whether the vent plug is removed and if the mounting orientation of the gearbox is correct, see section 4;
- Contact the installer when the cause of oil leakage is not related to installation error.

Fault: humming noise from motor

- Check the voltages on all three phases, which should all be the same and correspond to the value on the motor rating plate;
- Check that all nuts on the terminal block are properly tightened;
- Contact the installer if the fault persists.

9. Wiring diagram 400V 3~ supply

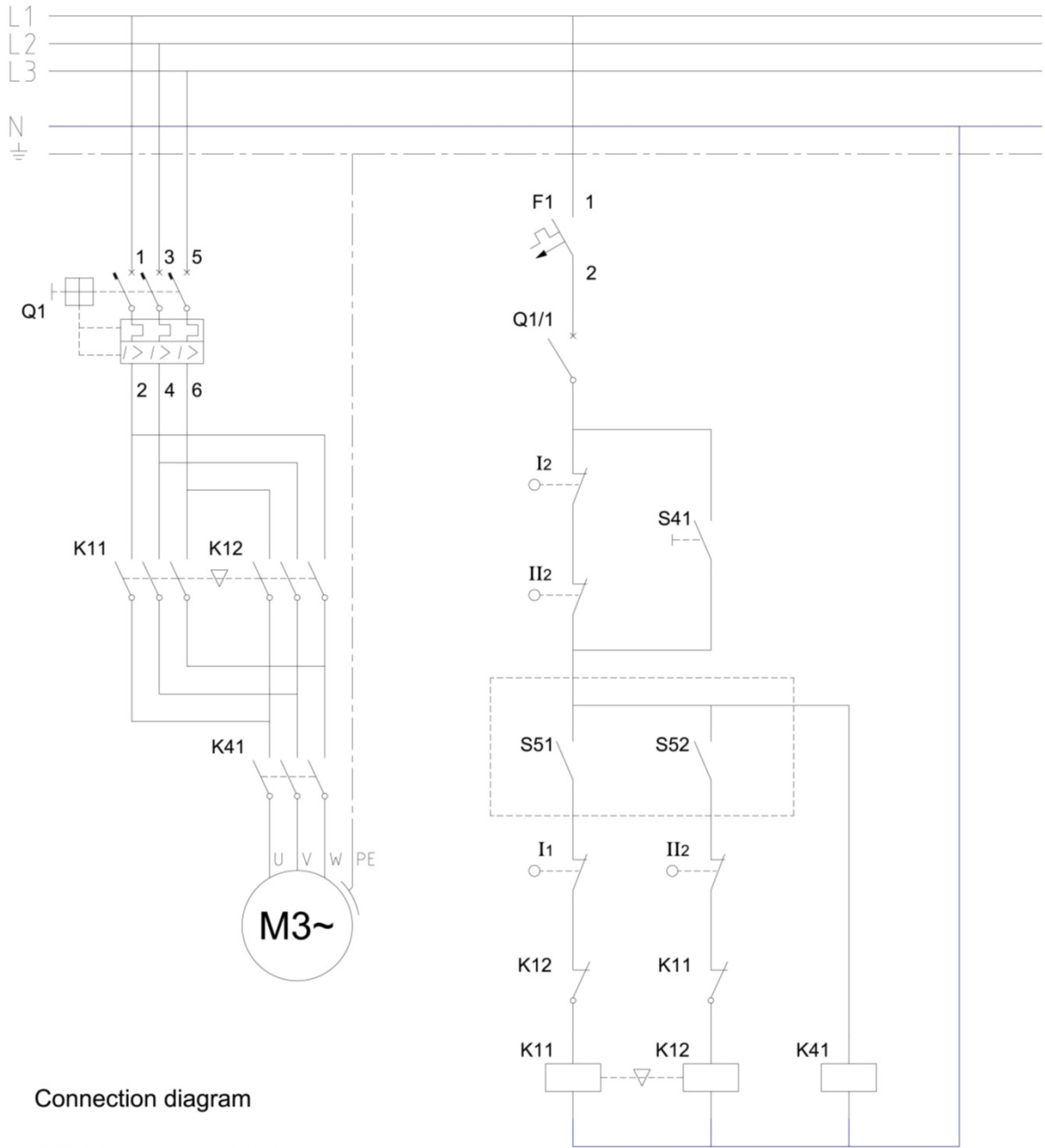

Connection diagram

△ 230V 3~ ▲ 400V 3~

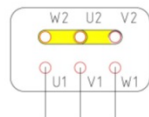
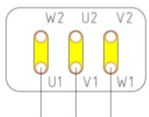

- I1, II1, I2, II2: Limitswitch contacts
- S41: Emergency stop by-pass button
- S51: External control relay - direction I
- S52: External control relay - direction II
- K41: Emergency stop relay
- Fixed connection plate

Voltage on limitswitch [V]	Minimum current [mA]	Maximum current [A]
230	50	1.5
24	200	0.5

Glossary

S3-30%	Duty cycle as defined in IEC 60034-1: Intermittent periodic operation with the motor active at most 30% of the time.
AC	Alternating Current.
Protective cover	Cover to prevent direct contact between people, rain, dust and the motor gearbox.
Axial	In the length direction of the shaft.
Tightening torque [Nm]	Torque to which a bolted joint has to be tightened in units of in Newton-metre.
dB(A)	Intensity of sound, expressed in decibels
Operating hours counter	A counter used to register the number of actual operating hours of the drive unit.
Bi-metal	Temperature-sensitive protective switch.
Flexible coupling	A coupling which is able to compensate for alignment errors, for instance a chain coupling, universal joint or cardan shaft.
Dead-man vigilance system	Emergency switch actuated by a pull cord spanned along the entire length of the system.
Electrical ratings	The voltage, current and power values for which and electric motor is designed and which are shown on rating plate of the motor.
Hazard area	The area below or directly around the driven or moving parts.
Higher-level function	An overriding or governing switch condition, depending on the structure of the system, such as a rain signal that causes automatic operation of the motor gearbox.
Torque [Nm]	A measure of the rotational effect of a force. The magnitude of the torque is equal to the force time the radius (arm) and is expressed in Newton-metres.
Linear	Straight line
Gearbox	A gear unit that reduces the shaft speed of the input shaft.
Radial	Perpendicular to the shaft.
Relay	A switch operated by an electromagnet.
Residual risks	Risks which cannot reasonably be avoided (inherent in the product).
Strap	Hoisting equipment.
rpm	Revolutions per minute.
VAC	AC voltage
Fall-arrest protection brake	A protective device which stops descending loads if they are moving too fast.
Normally closed (NC) contact	An electrical contact that opens when the switch is actuated.
Viscosity	Fluidity or thickness of a liquid.
Self-braking	The gear unit can only be driven by the motor the output shaft cannot be moved by the load.